

Sintering behaviour of the diamond–super invar alloy system at high temperature and pressure

SHANG-JIE LI*, MINORU AKAISHI, TOSHIKAZU OHSAWA,
SHINOBU YAMAOKA

*National Institute for Research in Inorganic Materials, 1-1 Namiki, Tsukuba,
Ibaraki 305, Japan*

In the diamond–super invar alloy system, effect of the grain size of the starting diamond powder on the sintering behaviour was investigated at 5.8 GPa and 1300 to 1500°C for 30 to 60 min. Abnormal grain growth was often observed in the sintered diamond using fine diamond powder, but a homogeneous sintered diamond was easily synthesized using 5 to 10 μm diamond. By the rigorous control of sintering conditions, a 3 μm grain size homogeneous sintered diamond was synthesized under conditions of 5.8 GPa and 1350°C for 30 min. The Vickers hardness and thermal resistance of the fine grained sintered diamond was examined.

1. Introduction

Most sintered diamonds available commercially are synthesized by sintering diamond powder as a laminate on a WC–Co substrate at high temperature and high pressure [1, 2]. In the diamond/WC–Co system, cobalt in the WC–Co substrate infiltrates into the diamond particles and serves as an agent for forming diamond–diamond direct bonding.

These sintered diamond compacts have superior physical properties such as hardness, thermal conductivity, wear resistance, etc., but a large amount of cobalt metal (5.6 to 9.4 vol%, calculated from the reported density) is contained in the sintered mass [3, 4]. The large amount of metals causes a deterioration of the physical properties of the sintered mass at high temperature because catalytic graphitization of diamond easily occurs in the presence of the metals. Chipping and microcracking also occur as a result of thermal stress caused by the difference between thermal expansion coefficients of diamond and additive metal.

As an additive metal, super invar alloy is considered to be a desirable sintering agent from the view-point of the thermal expansion coefficient. It is expected that diamond sintered with super invar alloy will show a decrease in thermal stress at high temperature compared to that of diamond sintered with cobalt. In this context, we have recently reported the effect of additive metals on the thermal resistance property of diamond sintered with a small amount of metals (~ 1 vol%) synthesized under conditions of 7.7 GPa and 2000°C [5]. The thermal resistance property of the diamond sintered with super invar alloy was superior compared to those of diamonds sintered with cobalt or nickel in both graphitization and cracking. On the other hand, the sintering conditions in our report are considered to

be too severe for industrial purposes and a reduction in the sintered pressure and temperature is needed. Therefore, it is very important to investigate the sintering behaviour of the diamond–super invar alloy system in the 6 GPa region, which has not yet been reported. In this context, high temperature and high pressure experiments were carried out by placing diamond powder on a super invar alloy disc instead of WC–Co or cobalt, and the effects of temperature and the original grain size of the diamond powder on the sintering behaviour were examined. Physical properties, such as thermal resistance and hardness of the sintered diamond obtained were also examined.

2. Experimental procedure

The experiment was carried out using a modified belt-type high-pressure apparatus with 25 mm bore diameter, as reported by Akaishi *et al.* [6]. The sample assembly is shown in Fig. 1. As the starting material, three kinds of synthetic diamond powder with grain size of 0 to 1, 2 to 4 and 5 to 10 μm (Tomei Diamond Co, Hiratsuka, Kanagawa, 254, Japan) and super invar alloy disc (31 wt% Ni, 4 to 6 wt% Co, 0.3 to 0.4 wt% Mn, 0.87 wt% C, remainder Fe) were used.

Samples were first compressed to a pressure of 5.8 GPa, then heated to a temperature between 1300 and 1500°C, held for 30 to 60 min, cooled to room temperature and finally decompressed. The temperature was estimated from the predetermined relation between input electrical power and Pt 6% Rh–Pt 30% Rh thermocouple e.m.f. at 5.8 GPa using a similar sample assembly to that shown in Fig. 1. The pressure effect on the thermocouple e.m.f. was not corrected. The pressure was determined by using the known phase transitions of Bi(2.5 GPa), Tl(3.6 GPa) and Ba(5.5 GPa).

*Permanent address: Zhengzhou Research Institute of Abrasives and Grinding, China.

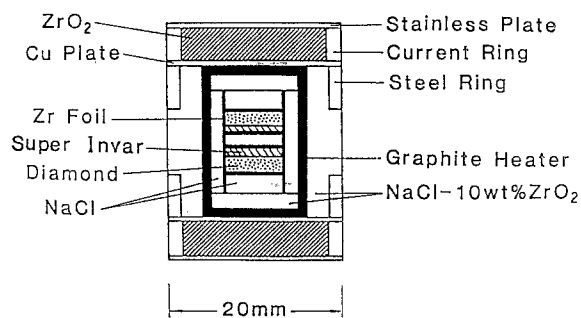

Figure 1 Sample assembly for high-pressure sintering.

All the experiments were carried out at a pressure of 5.8 GPa. The sintering temperature was chosen in such a way that a sample should be above the eutectic temperature of the diamond–super invar alloy system in the diamond stable region. The eutectic point of this system at high pressure has not been reported. However, in the diamond synthesis experiments using super invar alloy, the lower temperature limit of the system, which corresponds to the eutectic point, was almost equal to that of cobalt metal. The eutectic temperature of the diamond–Co system was about 1336°C at 5.6 GPa [7]. Based on this result, a sintering temperature range of 1350 to 1500°C was chosen for this study. The starting materials and their sintering conditions are listed in Table I.

The samples obtained were ground with a diamond wheel and cut or fractured, and then, if necessary, these fractured surfaces were treated by hot hydrochloric acid to remove super invar alloy on the surface. After grinding, samples were investigated by X-ray diffraction. The surfaces were observed through an optical microscope, secondary electron image (SEI) or backscattered electron image (BEI) of a scanning electron microscope and an energy dispersive X-ray micro-analyser (EDX). The polished samples were

TABLE I Starting diamond powders and sintering conditions

Sample no.	Diamond powders (μm)	Sintering temp. ($^{\circ}\text{C}$)	Time (min)
A	0–1	1350	60
B	0–1	1400	60
C	0–1	1450	60
D	0–1	1500	60
E	2–4	1300	60
F	2–4	1350	60
G	2–4	1400	60
H	2–4	1450	60
I	2–4	1500	60
J	2–4	1350	30
K	2–4	1400	30
L	5–10	1350	60
M	5–10	1400	60
N	5–10	1450	60
P	5–10	1500	60

used for hardness measurements and the investigation of thermal resistance. Polishing was done using rotating cast iron scaife. Vickers hardness was measured with a normal load of 19.6 N. Thermal resistance was examined by heat treatment at 900°C for 30 min in a vacuum of 10^{-3} Pa.

3. Results and discussion

3.1. Sintering behaviour of diamond–super invar alloy

It was found that super invar alloy was infiltrated into the diamond layer to a greater or lesser degree in all the experiments above 1350°C. There was no difference in the infiltration between the upper and lower samples in Fig. 1. This result is quite similar to that of our previous paper on the diamond–cobalt system [8].

Fig. 2 shows the BEI of samples A, B, C and D listed in Table I, where the starting diamond particles

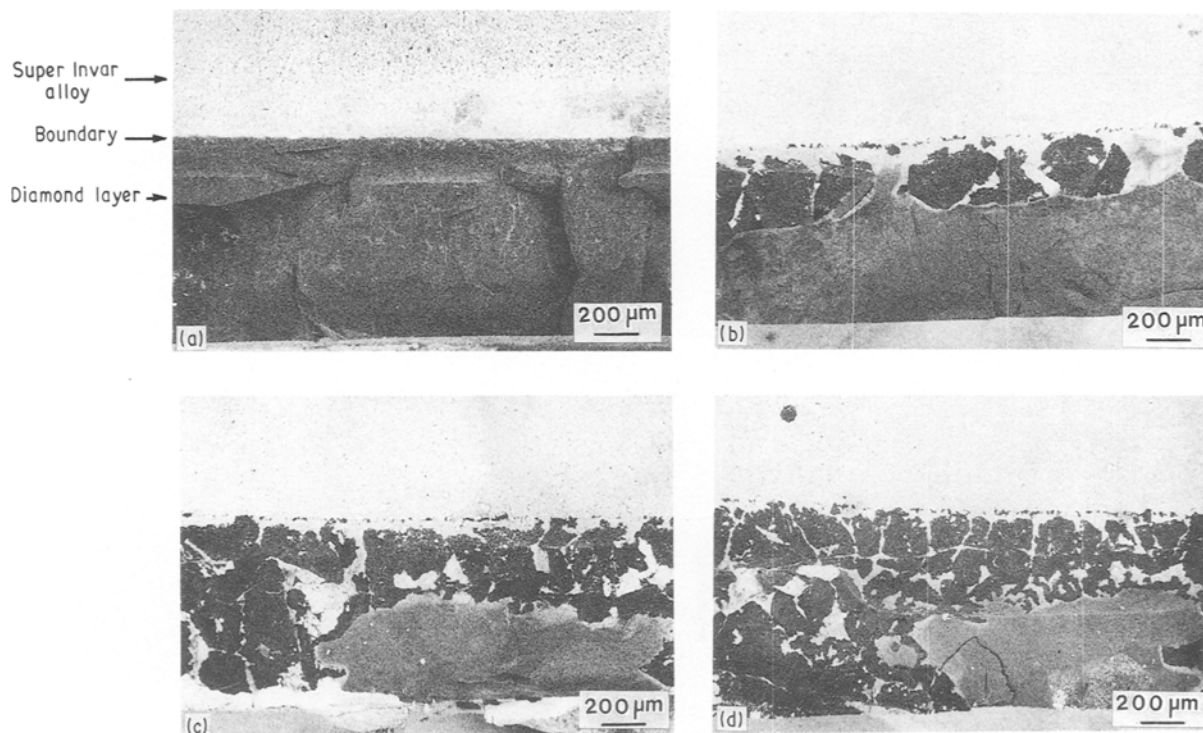

Figure 2 BEI of fractured surface of samples (a) A, (b) B, (c) C and (d) D.

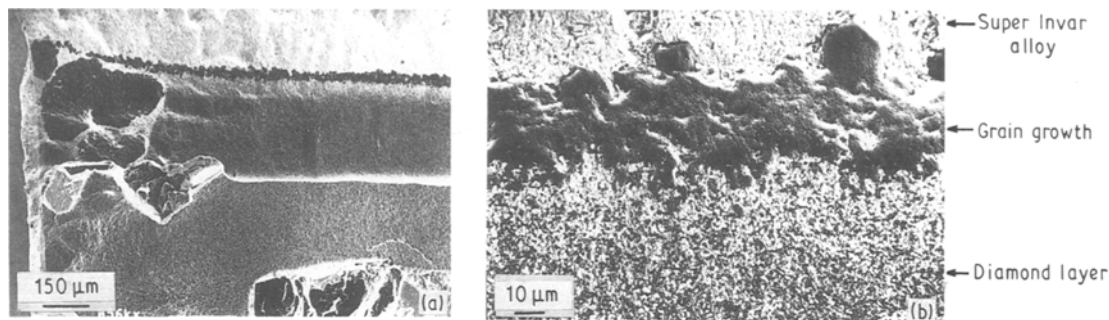

Figure 3 SEI of fractured surface in sample F obtained at 1350°C for 60 min.

were very fine, less than 1 μm) and the holding time was 60 min. The lighter area corresponds to metals and the darker one to diamond. From the figure it can be observed that in sample A, held at 1350°C, any abnormal grain growth was not observed in the diamond layer (Fig. 2a), but it has a weakly bonded region in the central part of the diamond layer; however, no graphite was detected in the sample by X-ray diffraction. Nor was any graphite detected in other samples. As shown in Figs 2b to d, an abnormal grain growth with grain size 50 to 400 μm was observed at the boundary and peripheral regions in samples B to D. The degree of abnormal grain growth was qualitatively increased with increasing sintering temperature. As described above, it is very difficult to synthesize the homogeneous sintered body with high hardness when 0 to 1 μm diamond powder is used as a starting material. These results suggest that a more rigorous control of sintering temperature and holding time is necessary for this purpose.

In order to determine the lower temperature limit of super invar alloy infiltration into the diamond layer, a sample with a grain size of 2 to 4 μm was treated at 1300°C for 60 min (sample E). In this sample, no metal infiltration was observed in the diamond layer.

This result suggests that in diamond–super invar alloy system, the eutectic temperature at 5.8 GPa is higher than 1300°C. In samples with the same grain size treated above 1350°C, super invar alloy infiltration was observed in all samples F, G, H and I. In sample F treated at 1350°C, some abnormal grain growth with a grain size of a several hundred micrometres was observed in the diamond layer as shown in Fig. 3a. Fig. 3b shows an enlargement of the boundary area between super invar alloy and the diamond layer. Also, abnormal grain growth with about 40 to 80 μm grain size can be clearly seen in this figure. Severe abnormal grain growth was observed in the diamond layers in samples G, H and I treated above 1400°C.

On the other hand, in samples L and M with a fairly large original grain size of 5 to 10 μm, super invar alloy infiltrated homogeneously throughout the diamond layer. As shown in Figs 4a and c, no abnormal grain growth was observed in the diamond layer, but in the boundary region a small amount of abnormal grain growth was observed. The degree of these abnormal grain growth regions increased with increasing sintering temperature as shown in Figs 4b and d.

As described above, extremely abnormal grain growth was observed in samples B, C, D, G, H and I

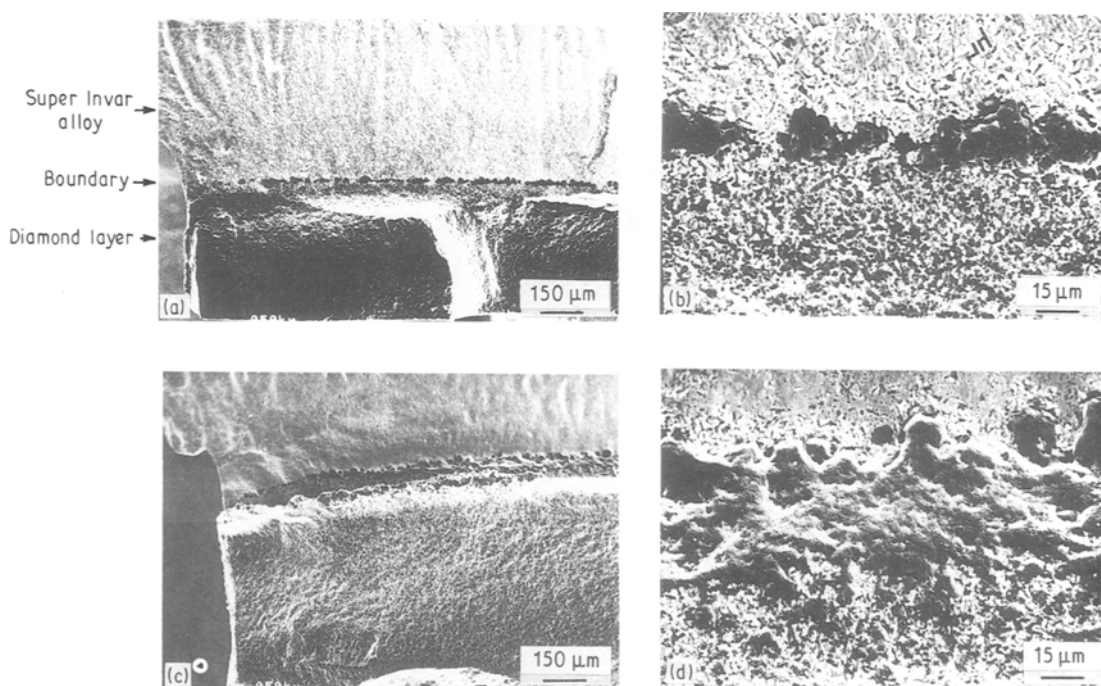

Figure 4 SEI of fractured surface in samples L and P. (a) Sample L (1350°C), (b) enlargement of the boundary region of sample L, (c) sample P (1500°C), (d) enlargement of the boundary region of sample P.

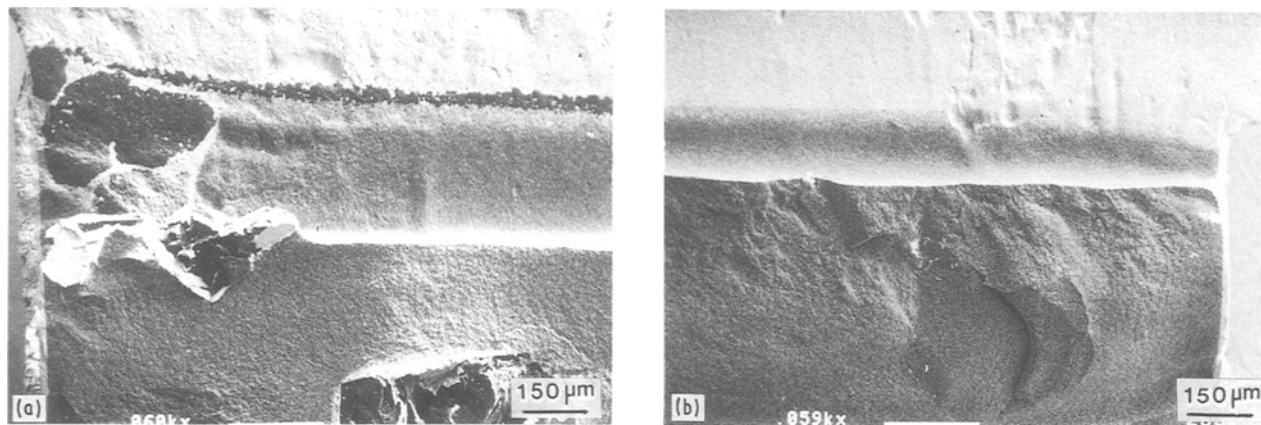

Figure 5 BEI of fractured surface in sample F and J. (a) Sample F (1350°C for 60 min), (b) sample J (1350°C for 30 min).

obtained above 1400°C using diamond powders with a small grain size, such as 0 to 1 or 2 to 4 μm. However, in the case of 5 to 10 μm diamond powder, no abnormal grain growth was observed in the diamond layer. These results suggest that it is very difficult to synthesize sintered diamond with a fairly small grain size compared to that with a fairly large grain size, such as 5 to 10 μm. The surface energy of fine diamond powder is larger than that of coarse powder. Therefore, the abnormal grain growth occurs easily in the sintered diamond using a fine powder as a starting material.

To obtain a sintered diamond without abnormal grain growth, a more rigorous control of sintering temperature and holding time was made in the diamond–super invar alloy system when a diamond powder of 2 to 4 μm was used as a starting material.

3.2. Synthesis of sintered diamonds with homogeneous microstructure

As described in the previous section, a small amount of abnormal grain growth was observed in the sintered diamond obtained at 1350°C for 60 min using a diamond powder to 2 to 4 μm. The sintered diamond, except for the abnormal grain growth region, has a homogeneous microstructure with a fairly high hardness when considering the grinding resistance of the same sample. This result suggests that the sintering temperature is considered to be high enough, but the

holding time is too long. Therefore, abnormal grain growth occurred in the diamond layer under conditions of 1350°C for 60 min.

To obtain a homogeneous sintered diamond with high hardness, a 2 to 4 μm diamond powder laminated on a super invar alloy disc was treated for a shorter holding time of 30 min at the same temperature (sample J). As shown in Fig. 5, the microstructure of sample J is quite different compared to that of sample F. No abnormal grain growth was observed in sample J. To clarify the sintering conditions required to obtain a sintered diamond with homogeneous microstructure, a diamond powder with the same grain size was treated at 1400°C for 30 min. A small amount of abnormal grain growth was observed in this sample. The synthesis conditions of the sintered diamond with a homogeneous microstructure were limited to a very narrow range.

More detailed observation of the same sample was made to determine the metal distribution and microstructure. The distribution of the super invar alloy was investigated by a line analysis of FeKα, NiKα and CoKα in EDX along the ground section of the sample. Fig. 6 shows the distribution of iron concentration. As shown in the figure, the iron content gradually decreases at the boundary and then the concentration is homogeneous throughout the diamond layer. The distributions of nickel and cobalt also showed a similar tendency to that of iron. From these results it can be said that the super invar alloy was distributed homogeneously in the diamond layer.

In order to investigate the detailed microstructure of the present sample, the fractured surface was observed by SEM. As shown in Fig. 7a, this sintered diamond has a homogeneous microstructure without abnormal grain growth. Fig. 7b, the BEI of the same spot, shows that a lighter area was distributed homogeneously in the diamond layer which corresponds to the super invar alloy. The super invar alloy with fine grains was distributed homogeneously in the sintered diamond layer. This result is consistent with that of FeKα line analysis. It is very difficult to see the detailed microstructure from this figure. More detailed observation of the same fractured surface is shown in Fig. 8. This sintered diamond is considered to be a strongly bonded sintered mass of diamond grains. The

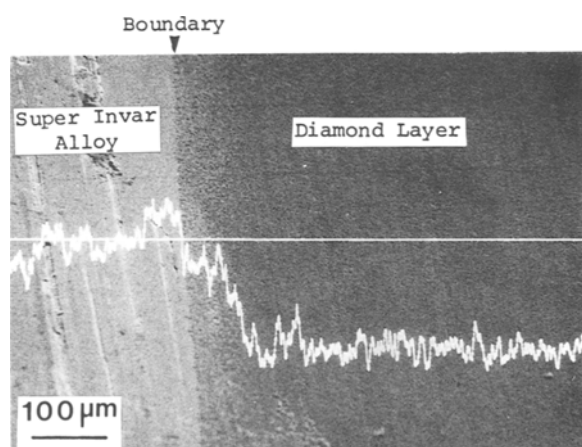

Figure 6 Distribution of iron concentration along the line in the ground section of sample J (FeKα by EDX).

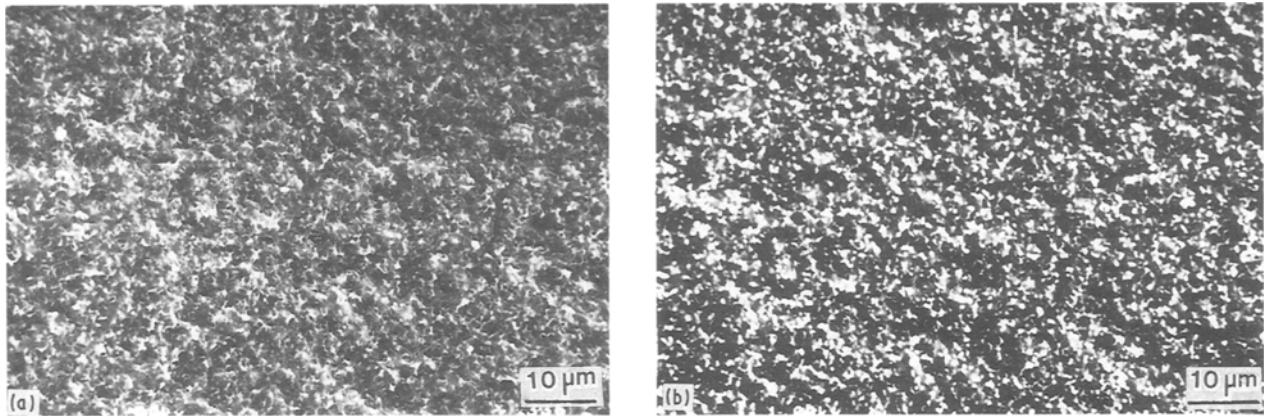

Figure 7 Scanning electron micrographs of fractured surface in sample J. (a) SEI, (b) BEI of the same spot in (a).

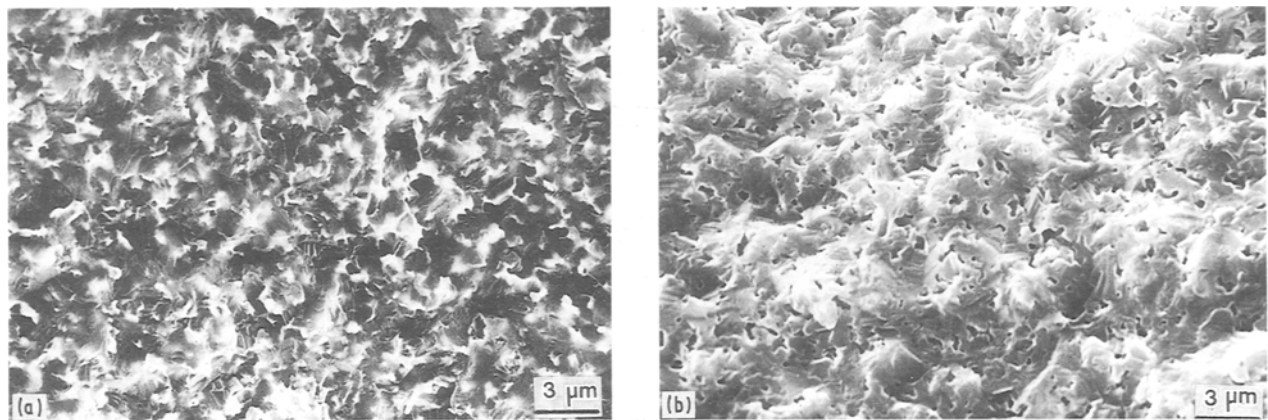

Figure 8 SEI of fractured surface in sample J. (a) As fractured surface, (b) after acid treatment of fractured surface.

grain size of the sintered body is not clear from Fig. 8a. Therefore, the fractured surface was treated with hot hydrochloric acid to remove the alloy from the surface. SEI of the fractured surface after acid treatment is shown in Fig. 8b. The grain size of the sintered diamond was about $3\ \mu\text{m}$. This size is almost the same as that of the starting material.

Strongly bonded sintered diamond with a grain size of about $3\ \mu\text{m}$ was synthesized at 1350°C for 30 min. It is very interesting to investigate the physical properties of the sintered diamond.

3.3. Hardness and thermal resistance

The homogeneous sintered diamond with a grain size

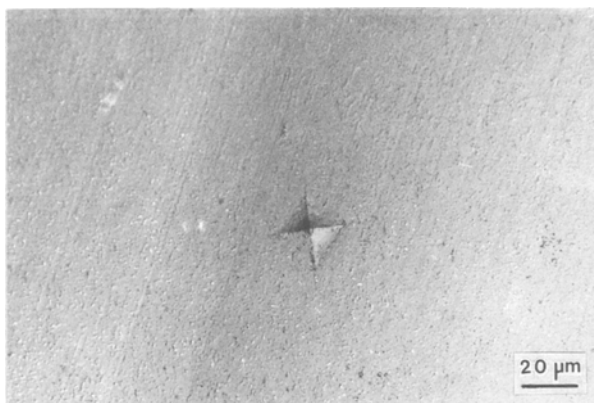

Figure 9 Optical micrograph of the indented surface of sample J (differential interference microscopy).

of about $3\ \mu\text{m}$, sample J, was polished using a rotating cast iron scribe. The polished sample was used for Vickers hardness measurement and the investigation of the thermal resistance.

In the indentation hardness measurement, it is very difficult to get a clear indentation trace on superhard materials such as sintered diamond and cubic boron nitride. To make an accurate hardness measurement, the Vickers hardness was measured with a fairly high normal load of 19.6 N using a well-polished sintered diamond. As shown in Fig. 9, a very clear indentation trace could be observed on the polished surface. The

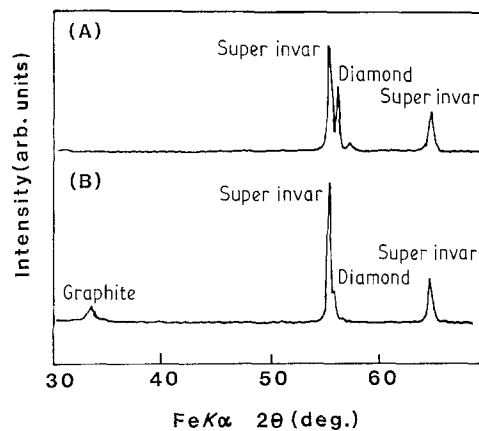

Figure 10 X-ray diffraction pattern of sample J before and after heat treatment. (a) Before heat treatment, (b) after heat treatment. Heat treatment 900°C for 30 min in vacuum.

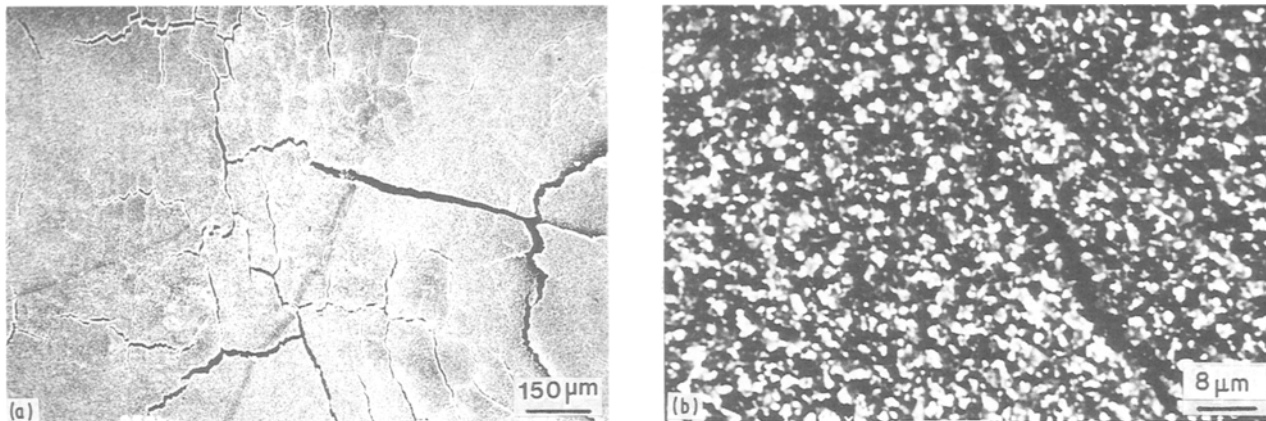

Figure 11 Scanning electron micrographs of the polished surface after heat treatment in sample J. (a) SEI, (b) BEI. Heat treatment 900°C for 30 min in vacuum.

hardness was calculated from five measurements of the diagonal of such clear indenter traces. The average value of the Vickers hardness was 55 ± 5 GPa. The homogeneous sintered diamond was a fairly hard material.

Thermal resistance of the polished sintered diamond, sample J, was examined by heat treatment at 900°C for 30 min in a vacuum of 10^{-3} Pa. Before and after heat treatment the sample was investigated by X-ray diffraction. As shown in Fig. 10, a large amount of diamond transformed to graphite by the catalytic action of super invar alloy.

Many cracks were also observed on the polished surface after heat treatment as shown in Fig. 11a. BEI observation of the same sample showed many tiny alloy particles with a size of $< 1 \mu\text{m}$ to a few micrometres on the polished surface. In order to examine the microstructure of the sample after heat treatment, a fractured surface was investigated by SEM as shown in Fig. 12. From the figure the microstructural difference in the grain shape and metal distribution before and after heat treatment is clearly seen. Diamond grains after heat treatment are not clear compared to those before treatment. The particle size and distribution of the alloy after heat treatment are quite different and the features are inhomogeneous compared to those before treatment.

A comparatively large amount of alloy phase present in the sintered diamond is unfavourable for good

thermal resistance in both graphitization and cracking. Although super invar alloy has a very low thermal expansion coefficient compared to those of iron, nickel and cobalt, the thermal resistance of the sintered diamond with a large amount of super invar alloy was not improved. These results suggest that the synthesis of sintered diamond with a small amount of metal or alloys is necessary to improve the thermal resistance property.

4. Conclusions

1. In the diamond–super invar alloy system, it is very difficult to obtain a homogeneous sintered diamond without abnormal grain growth using a diamond powder with a fairly small grain size such as 0 to 1 and 2 to 4 μm . In the case of diamond powder with 5 to 10 μm grain size, homogeneous sintered diamond was easily obtained at 5.8 GPa and 1350 to 1500°C.

2. Homogeneous sintered diamond with 3 μm grain size was synthesized at 5.8 GPa and 1350°C for 30 min.

3. The Vickers hardness of the above diamond was 55 ± 5 GPa. A large amount of graphitization and many cracks were observed in the sintered diamond after heat treatment at 900°C for 30 min in vacuum.

References

1. R. H. WENTORF Jr and W. A. ROCCO, US Pat.

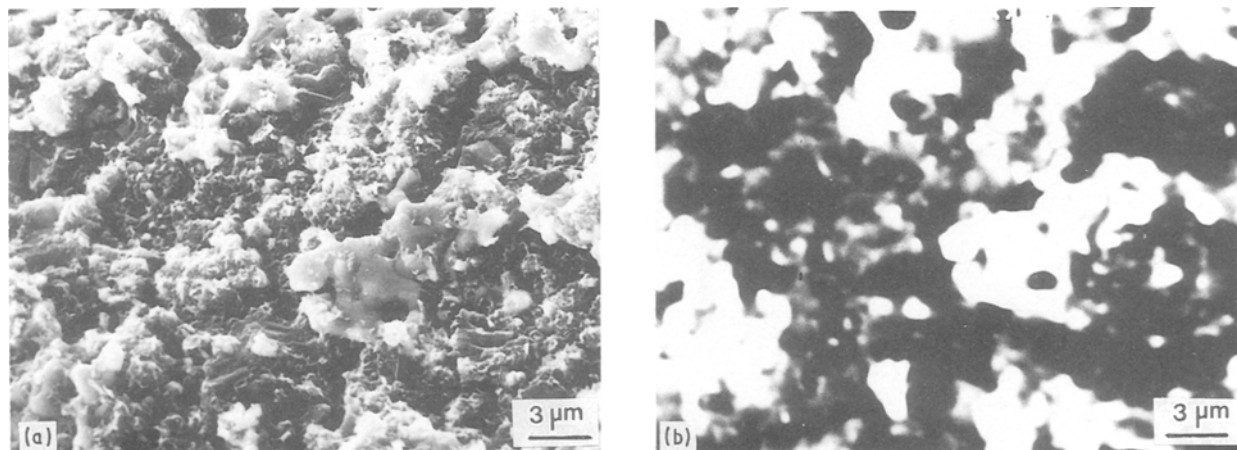

Figure 12 Scanning electron micrographs of the fractured surface after heat treatment in sample J. (a) SEI, (b) BEI.

- 3 745 623, 17 July 1973.
2. *Idem*, US Pat. 3 767 371, 23 October 1973.
 3. R. H. WENTORF Jr, R. C. DeVRIES and F. P. BUNDY, *Science* **208** (1980) 873.
 4. P. D. GIGL, "Strength of polycrystalline diamond compacts", edited by K. D. Timmerhaus and M. S. Barber "High Pressure Science and Technology", Vol. 1 (Plenum, New York, 1979) pp. 914-22.
 5. M. AKAISHI, T. OHSAWA, S. YAMAOKA and O. FUKUNAGA, Thermal property of the sintered diamond with small amount of metal, First International Conference on the New Diamond Science and Technology, 24-26 October 1988, Tokyo, Japan. To be published.
 6. M. AKAISHI, H. KANDA, Y. SATOH, N. SETAKA, T. OHSAWA and O. FUKUNAGA, *J. Mater. Sci.* **17** (1982) 193.
 7. H. M. STRONG and R. E. TUFT, Rep. no. 74CRD118, Technical Information Series, G. E. Research and Development, New York, 1974.
 8. S. M. HONG, M. AKAISHI, H. KANDA, T. OHSAWA, S. YAMAOKA and O. FUKUNAGA, *J. Mater. Sci.* **23** (1988) 3821.

*Received 12 April
and accepted 28 September 1989*